

Description:

Hydraulic intensifiers increase hydraulic pressure by a fixed ratio. With this method it is possible, e.g. to use a low-pressure machine hydraulic system for consumers that can profitably benefit from a pressure that is multiple higher.

The intensification is achieved by means of a fixed ratio between two pistons surface areas. That means that the secondary pressure can be controlled by means of the input pressure.

A non-return by-pass valve is available for the rapid filling of the hydraulic consumer.

Intensification starts automatically at approx. 20 bar. The oscillating pump action starts automatically when there is a flow rate through the intensifier. The intensification ends automatically when the consumer no longer requires a flow rate and the high pressure has been achieved.

The flow rate on the high pressure side depends on the attainable high pressure.

The more highly attained high pressure, the smaller the flow rate.

Operating conditions:

We recommend the use of a pressure filter with a filter mesh of max. 10 µm to guarantee optimal functioning (see data sheet 600-1).

As a result of structural design of this intensifier there is internal leakage, which is automatically drained off by means of the T-connection.

When consumers are uncoupled, it is recommended that an external pilot operated check valve (see data sheet 700-10) is installed between the intensifier and the consumer. This can be activated to open the T-line.



Webcode: 043002

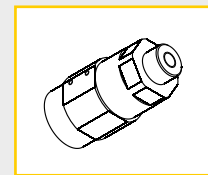

Intensifier with threaded port:

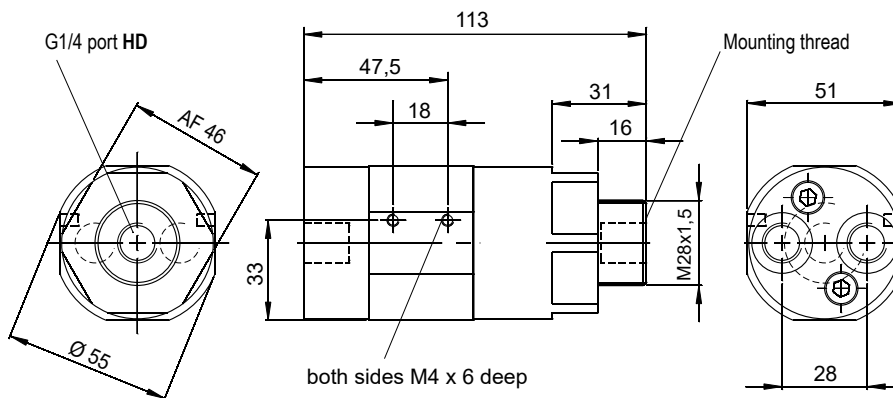

Functional diagram:

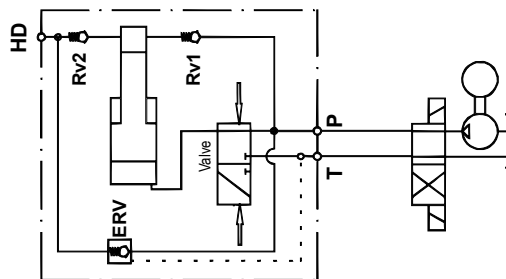

Technical data:

Intensification ratio	1,5 : 1	2 : 1	3,4 : 1	4 : 1	5 : 1
Max. flow rate QP low-pressure inlet [l/min]	8	8	15	14	14
Max. flow rate QHD high-pressure, start - end [l/min]	0,8 - 0,2	0,8 - 0,2	2,2 - 0,5	1,8 - 0,4	1,4 - 0,3
Max. operating pressure PP low-pressure inlet [bar]	200	200	200	200	160
Max. operating pressure PHD high-pressure outlet [bar]	300	400	680	800	800
Threaded connection P/T/HD	G1/4	G1/4	G1/4	G1/4	G1/4
Weight [kg]	1,3	1,3	1,3	1,3	1,3
Order number	DUHH...-15-5-001	...-20-5-001	...-34-5-001	...-40-5-001	...-50-5-001

Connections:

- ☒ G1/4 threaded port
- ☒ Manifold with O-ring
- ☒ CETOP NG 6 connection

Operating temperature:

- ☒ -40 °C up to +120 °C

Fluid media:

- ☒ Hydraulic oil to max. HLP 40
- ☒ HFC liquids with min. 5% Glycol

Important notice:

The life time of the hydraulic intensifiers is determined considerably by the filtration of the fluid media. A filtration grade of 10 µm must be ensured. (For filters see data sheet 600-1)

Accessories:

	Order no.
☒ hydraulic filter 10 µm	DUF-10-5-001
☒ pilot operated check valve	ERSV-500-5-001

We also design and manufacture customized variants!



- +49 6401 225999-0
- sales@hydrokomp.de
- Siemenstr. 16
35325 Mücke (Germany)
- www.hydrokomp.de



Dimensions for DUHF

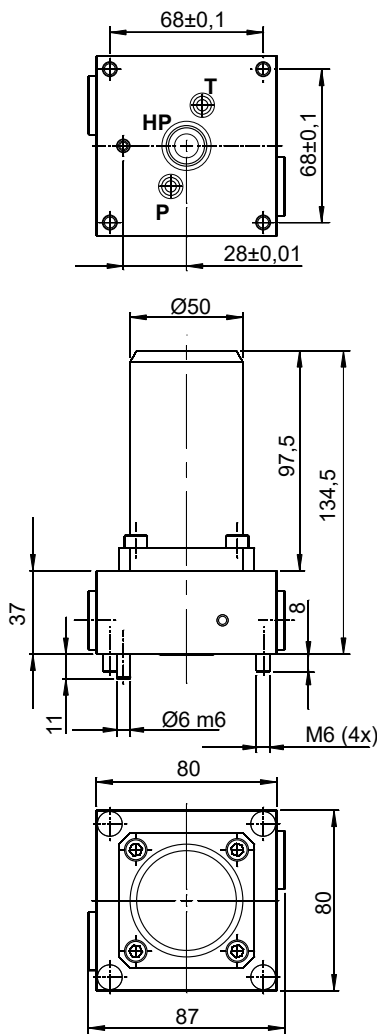

Dimensions for DUHH

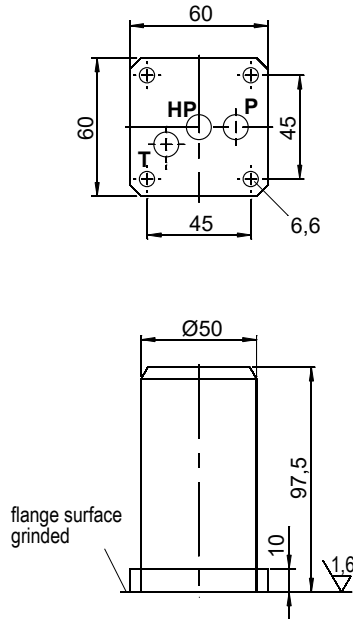

Description:

The hydraulic intensifier for manifold connection with O-rings can be equipped with a filter plate. The integrated filter with 10 µm filters all hydraulic connections in the influx. This protects the hydraulic intensifier optimally against contamination.

If the hydraulic intensifier should be installed on uncouplable hydraulic systems, an additional pilot operated check valve must be installed between the intensifier and the hydraulic consumer.

Spare parts:

- ☒ **Filter for filter plate for DUHF**
(suitable for all sizes)
Order no.: DUF-10-5-003

Connections:

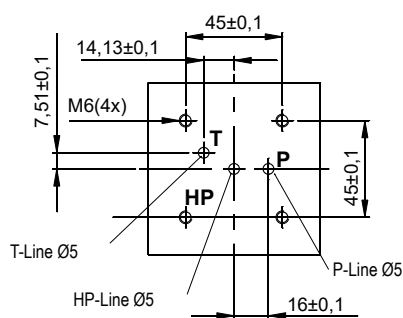

Technical data:

Intensification ratio	2 : 1	3,4 : 1	4 : 1	5 : 1	7 : 1
Min. flow rate, low-pressure side Q _P	[l/min] 2	2	2	2	2
Max. flow rate, low-pressure side Q _P	[l/min] 8	15	14	14	13
Max. flow rate, high-pressure side Q _{HD} start - end ⁽¹⁾	[l/min] 0,8 - 0,2	2,2 - 0,5	1,8 - 0,4	1,4 - 0,3	1,1 - 0,2
Max. operating pressure, low-pressure side P _P	[bar] 200	200	175	140	100
Max. operating pressure, high-pressure side P _{HD}	[bar] 400	680	700	700	700
Order no. without filter plate	DUHH-20-5-002	DUHH-34-5-002	DUHH-40-5-002	DUHH-50-5-002	DUHH-70-5-002
Weight	[kg] 1,5	1,5	1,5	1,5	1,5
Order no. with filter plate	DUHF-20-5-003	DUHF-34-5-003	DUHF-40-5-003	DUHF-50-5-003	DUHF-70-5-003
Weight	[kg] 3,0	3,0	3,0	3,0	3,0

⁽¹⁾ The flow rate on the high pressure side depends on the attainable high pressure. The more highly attained high pressure, the smaller the flow rate.

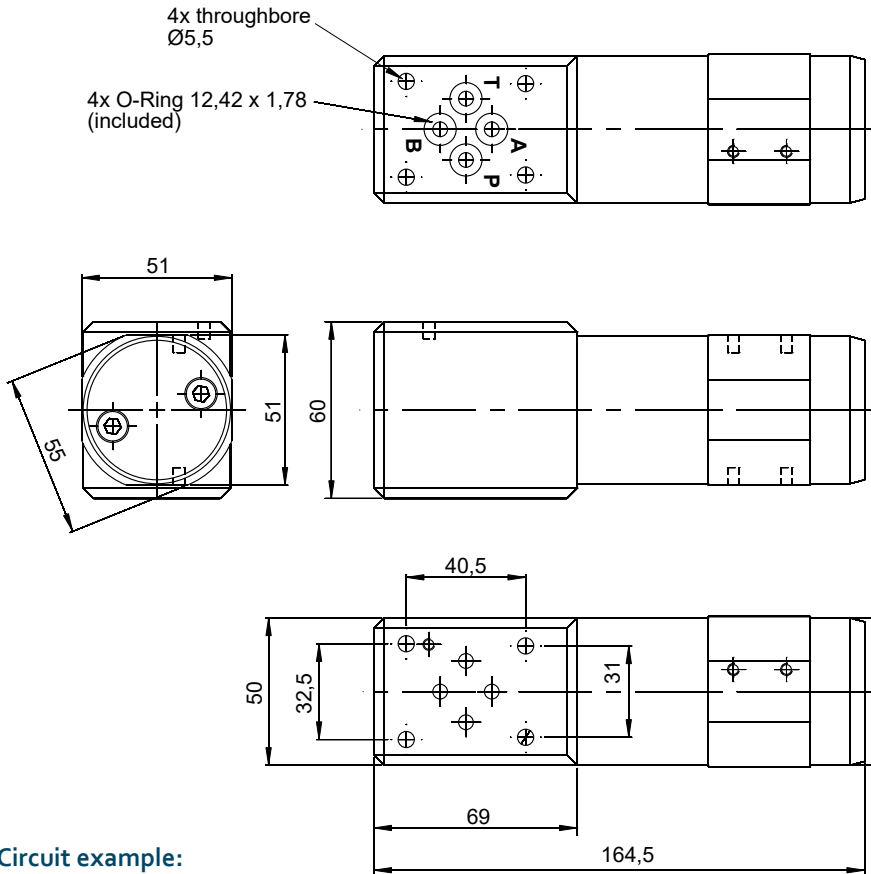

Description:

These hydraulic intensifiers are designed for the mounting between the plates in a NG 6 hydraulic system and increase the supplied low pressure according the intensification to max. 500 bar.

The control of these hydraulic intensifiers takes place via a NG 6 valve, which is installed on the supply side (circuit example).

All further valve functions, inclusive pilot operated check valve, are integrated in the housing of the hydraulic intensifier.

Spare parts:

- ⊗ O-Ring 12,42 x 1,78 (suitable for all sizes)
Order no.: 6012-007

Circuit example:

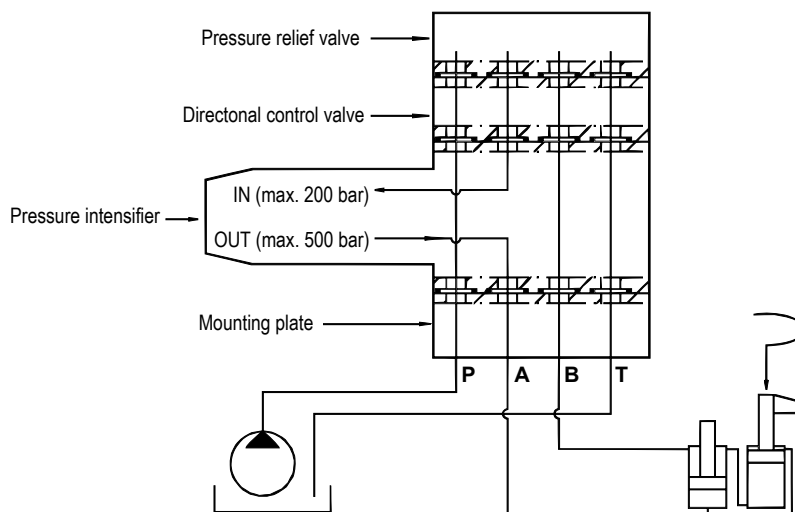

Technical data:

Intensification ratio		1,5 : 1	2 : 1	3,4 : 1	4 : 1	5 : 1	7 : 1	9 : 1
Min. flow rate Q_P low-pressure side	[l/min]	2	2	2	2	2	2	2
Max. flow rate Q_P low-pressure side	[l/min]	8	8	15	14	14	13	13
Max. flow rate Q_{HD} high-pressure, start - end ⁽²⁾	[l/min]	0,8 - 0,2	0,8 - 0,2	2,2 - 0,5	1,8 - 0,4	1,4 - 0,3	1,1 - 0,2	0,7 - 0,1
Max. low pressure PP	[bar]	200	200	147	125	100	71	56
Max. high pressure PHD	[bar]	300	400	500	500	500	500	500
Weight	[kg]	2,65	2,65	2,65	2,65	2,65	2,65	2,65
Order number	DUHH...	...15-NG6-001	...20-NG6-001	...34-NG6-001	...40-NG6-001	...50-NG6-001	...70-NG6-001	...90-NG6-001

⁽²⁾ The flow rate on the high pressure side depends on the attainable high pressure. The more highly attained high pressure, the smaller the flow rate.